

Twist-Strip[®]

TSK8000 - TSK8500

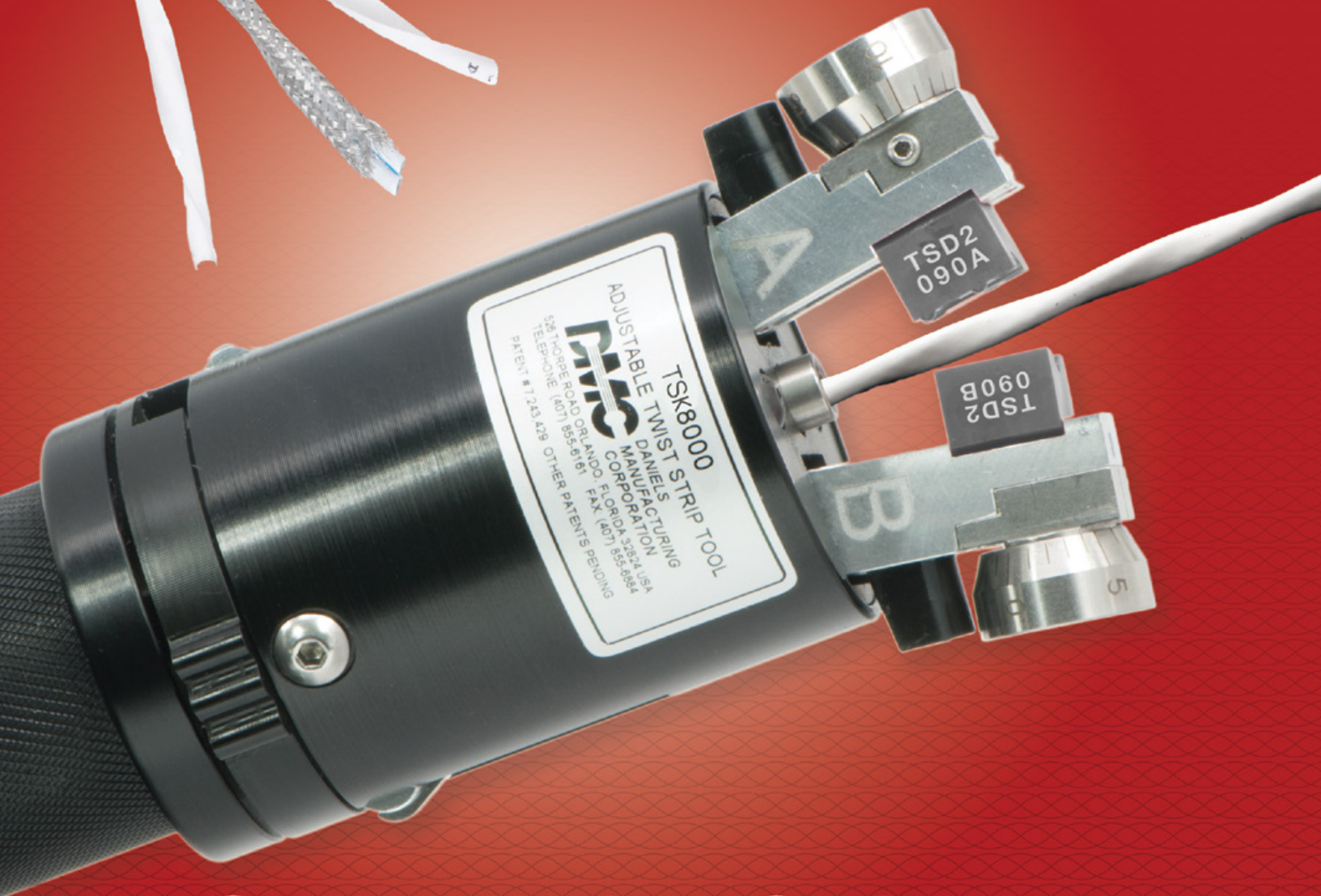

Outer Jacket Stripper For Shielded Twisted Cable

Daniel **MANUFACTURING**[®]
CORPORATION
An ISO9001-2008 and AS9100C Registered Company

Safe, Accurate, and Repeatable

The Problem

It is common for high-speed data cable to utilize two or more shielded twisted conductors. This type of cable is common in all digital electronic networks, and it requires new tooling disciplines. The challenge in designing a wire prep system of this type is the non-circular configuration of the cable, and the many types, variations, and stripping nuances of shielded, twisted, multi-wire cable.

Imprecise Methods

Stripping multi-conductor wire cable is often done by hand with a razor blade. This is a dangerous and difficult way to remove the jacket from any type of electrical cable. A razor blade offers no method of controlling the depth of cut which will result in a poor quality strip, and cuts or scrapes on the shielding which lead to poor electrical bond and a likely place for corrosion.



Risk of Injury

Using a razor blade increases the probability of injury to the operator and constant tugging to remove the outer jacket which causes operator fatigue. Other methods for removal of the jacket like laser or thermal stripping produce hazardous work environments.



Time Consuming

The conventional "ring and slit" method for stripping shielded twisted cable is very time consuming and requires a highly skilled operator to successfully perform.

The Solution

The DMC Twist-Strip® product line gives the user a system with the maximum capabilities, while keeping the system portable, self-contained, affordable, and ergonomic. The precise blade adjustment, zero friction ball bearing design, articulating/locking arms, and changeable dies makes the Twist-Strip very user-friendly and efficient when performing the difficult task of cable preparation.

Adjustable (New Feature)

The TSK8000 and TSK8500 have adjustable blades that allow the tool to accommodate variances in the cable. Varying jacket thickness and cable diameter are two examples of common differences you may see in different lots of the same cable. Simple adjustments allow the user to set the cutting blades for a deeper or shallower score of the cable jacket.

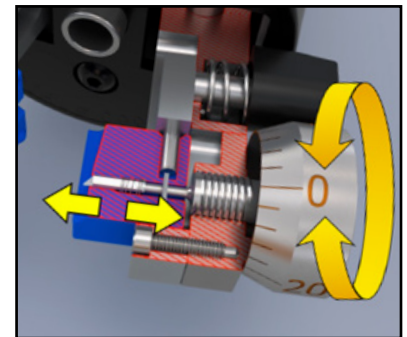

Precise

A cable track precisely machined into each die set creates a controlled rotation of the dies/blades as the cable is moved along the cable. A simple 90° bend of the cable results in the jacket halves separating for removal, reducing the amount of force needed to remove the jacket.



Consistent

The repeatable function of the tool reduces operator error and is up to 3 to 5 times faster than conventional methods.

TSK8000 Die Set Selection

TSK8000 Die Set Part Numbering System - 1 Inner Conductor					
Tool Frame PN	Die Set PN	MIL Die Set PN	Conductors	Cable OD Range	Cable Lay
TSK8000	TSD1070	N/A	1	.061 to .070"	N/A
TSK8000	TSD1080	N/A	1	.071 to .080"	N/A
TSK8000	TSD1090	N/A	1	.081 to .090"	N/A
TSK8000	TSD1100	N/A	1	.091 to .100"	N/A
TSK8000	TSD1110	N/A	1	.101 to .110"	N/A
TSK8000	TSD1120	N/A	1	.111 to .120"	N/A
TSK8000	TSD1130	N/A	1	.121 to .130"	N/A
TSK8000	TSD1140	N/A	1	.131 to .140"	N/A
TSK8000	TSD1150	N/A	1	.141 to .150"	N/A
TSK8000	TSD1160	N/A	1	.151 to .160"	N/A
TSK8000	TSD1170	N/A	1	.161 to .170"	N/A
TSK8000	TSD1180	N/A	1	.171 to .180"	N/A

Cable Measurement Method One Conductor

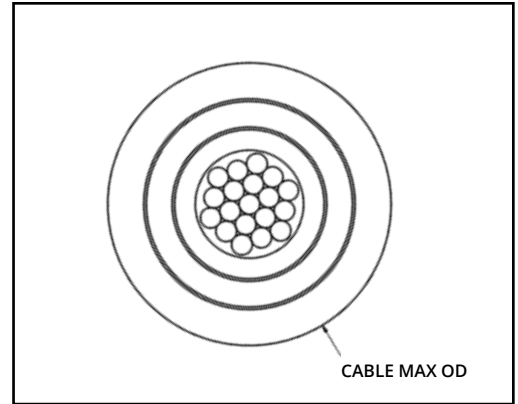

TSK8000 Die Set Part Numbering System - 2 Inner Conductors					
Tool Frame PN	Die Set PN	MIL Die Set PN	Conductors	Cable OD Range	Cable Lay
TSK8000	TSD2090	M32610/01-03	2	.081 to .090"	Left Lay
TSK8000	TSD2100	M32610/01-04	2	.091 to .100"	Left Lay
TSK8000	TSD2110	M32610/01-05	2	.101 to .110"	Left Lay
TSK8000	TSD2120	M32610/01-06	2	.111 to .120"	Left Lay
TSK8000	TSD2130	M32610/01-07	2	.121 to .130"	Left Lay
TSK8000	TSD2140	M32610/01-08	2	.131 to .140"	Left Lay
TSK8000	TSD2150	M32610/01-09	2	.141 to .150"	Left Lay
TSK8000	TSD2160	M32610/01-10	2	.151 to .160"	Left Lay
TSK8000	TSD2170	M32610/01-11	2	.161 to .170"	Left Lay
TSK8000	TSD2180	M32610/01-12	2	.171 to .180"	Left Lay

Cable Measurement Method Two Conductor

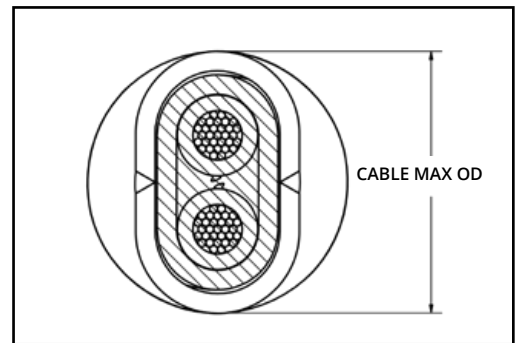

TSK8000 Die Set Part Numbering System - 3 Inner Conductors					
Tool Frame PN	Die Set PN	MIL Die Set PN	Conductors	Cable OD Range	Cable Lay
TSK8000	TSD3090	M32610/01-13	3	.081 to .090"	Left Lay
TSK8000	TSD3100	M32610/01-14	3	.091 to .100"	Left Lay
TSK8000	TSD3110	M32610/01-15	3	.101 to .110"	Left Lay
TSK8000	TSD3120	M32610/01-16	3	.111 to .120"	Left Lay
TSK8000	TSD3130	M32610/01-17	3	.121 to .130"	Left Lay
TSK8000	TSD3140	M32610/01-18	3	.131 to .140"	Left Lay
TSK8000	TSD3150	M32610/01-19	3	.141 to .150"	Left Lay
TSK8000	TSD3160	M32610/01-20	3	.151 to .160"	Left Lay
TSK8000	TSD3170	M32610/01-21	3	.161 to .170"	Left Lay
TSK8000	TSD3180	M32610/01-22	3	.171 to .180"	Left Lay

Cable Measurement Method Three Conductor

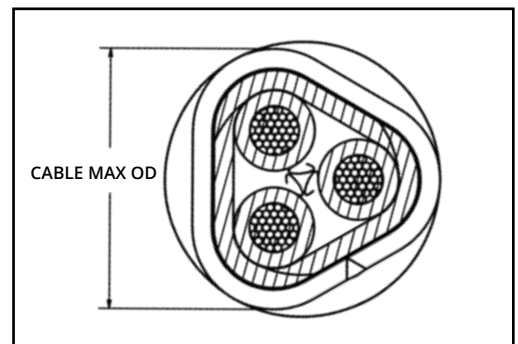

TSK8000 Die Set Part Numbering System - 4 Inner Conductors					
Tool Frame PN	Die Set PN	MIL Die Set PN	Conductors	Cable OD Range	Cable Lay
TSK8000	TSD4100	N/A	4	.091 to .100"	Left Lay
TSK8000	TSD4110	N/A	4	.101 to .110"	Left Lay
TSK8000	TSD4120	N/A	4	.111 to .120"	Left Lay
TSK8000	TSD4130	N/A	4	.121 to .130"	Left Lay
TSK8000	TSD4140	N/A	4	.131 to .140"	Left Lay
TSK8000	TSD4150	N/A	4	.141 to .150"	Left Lay
TSK8000	TSD4160	N/A	4	.151 to .160"	Left Lay
TSK8000	TSD4170	N/A	4	.161 to .170"	Left Lay
TSK8000	TSD4180	N/A	4	.171 to .180"	Left Lay

Cable Measurement Method Four Conductor

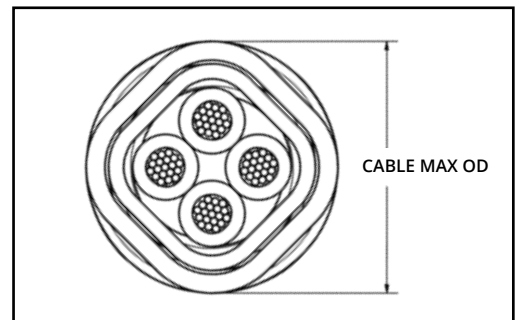

TSK8500 Die Set Selection

TSK8500 Die Set Part Numbering System - 1 Inner Conductor

Tool Frame PN	Die Set PN	# of Conductors	Cable OD Range	Cable Lay
TSK8500	TSDL1190	1	.181 to .190	N/A
TSK8500	TSDL1200	1	.191 to .200	N/A
TSK8500	TSDL1210	1	.201 to .210	N/A
TSK8500	TSDL1220	1	.211 to .220	N/A
TSK8500	TSDL1230	1	.221 to .230	N/A
TSK8500	TSDL1240	1	.231 to .240	N/A
TSK8500	TSDL1250	1	.241 to .250	N/A
TSK8500	TSDL1260	1	.251 to .260	N/A
TSK8500	TSDL1270	1	.261 to .270	N/A
TSK8500	TSDL1280	1	.271 to .280	N/A
TSK8500	TSDL1290	1	.281 to .290	N/A
TSK8500	TSDL1300	1	.291 to .300	N/A
TSK8500	TSDL1310	1	.301 to .310	N/A

TSK8500 Die Set Part Numbering System - 2 Inner Conductors

Tool Frame PN	Die Set PN	# of Conductors	Cable OD Range	Cable Lay
TSK8500	TSDL2190	2	.181 to .190	Left Lay
TSK8500	TSDL2200	2	.191 to .200	Left Lay
TSK8500	TSDL2210	2	.201 to .210	Left Lay
TSK8500	TSDL2220	2	.211 to .220	Left Lay
TSK8500	TSDL2230	2	.221 to .230	Left Lay
TSK8500	TSDL2240	2	.231 to .240	Left Lay
TSK8500	TSDL2250	2	.241 to .250	Left Lay
TSK8500	TSDL2260	2	.251 to .260	Left Lay
TSK8500	TSDL2270	2	.261 to .270	Left Lay
TSK8500	TSDL2280	2	.271 to .280	Left Lay
TSK8500	TSDL2290	2	.281 to .290	Left Lay
TSK8500	TSDL2300	2	.291 to .300	Left Lay
TSK8500	TSDL2310	2	.301 to .310	Left Lay

TSK8500 Die Set Part Numbering System - 3 Inner Conductors

Tool Frame PN	Die Set PN	# of Conductors	Cable OD Range	Cable Lay
TSK8500	TSDL3190	3	.181 to .190	Left Lay
TSK8500	TSDL3200	3	.191 to .200	Left Lay
TSK8500	TSDL3210	3	.201 to .210	Left Lay
TSK8500	TSDL3220	3	.211 to .220	Left Lay
TSK8500	TSDL3230	3	.221 to .230	Left Lay
TSK8500	TSDL3240	3	.231 to .240	Left Lay
TSK8500	TSDL3250	3	.241 to .250	Left Lay
TSK8500	TSDL3260	3	.251 to .260	Left Lay
TSK8500	TSDL3270	3	.261 to .270	Left Lay
TSK8500	TSDL3280	3	.271 to .280	Left Lay
TSK8500	TSDL3290	3	.281 to .290	Left Lay
TSK8500	TSDL3300	3	.291 to .300	Left Lay
TSK8500	TSDL3310	3	.301 to .310	Left Lay

TSK8500 Die Set Part Numbering System - 4 Inner Conductors

Tool Frame PN	Die Set PN	# of Conductors	Cable OD Range	Cable Lay
TSK8500	TSDL4190	4	.181 to .190	Left Lay
TSK8500	TSDL4200	4	.191 to .200	Left Lay
TSK8500	TSDL4210	4	.201 to .210	Left Lay
TSK8500	TSDL4220	4	.211 to .220	Left Lay
TSK8500	TSDL4230	4	.221 to .230	Left Lay
TSK8500	TSDL4240	4	.231 to .240	Left Lay
TSK8500	TSDL4250	4	.241 to .250	Left Lay
TSK8500	TSDL4260	4	.251 to .260	Left Lay
TSK8500	TSDL4270	4	.261 to .270	Left Lay
TSK8500	TSDL4280	4	.271 to .280	Left Lay
TSK8500	TSDL4290	4	.281 to .290	Left Lay
TSK8500	TSDL4300	4	.291 to .300	Left Lay
TSK8500	TSDL4310	4	.301 to .310	Left Lay

Operation Overview

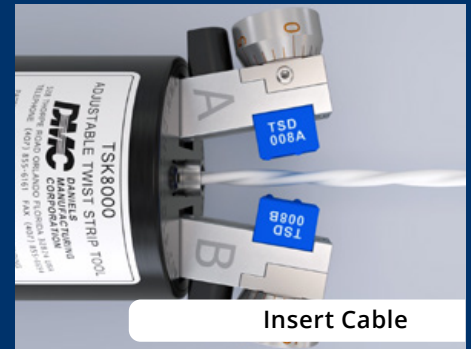

Insert Cable

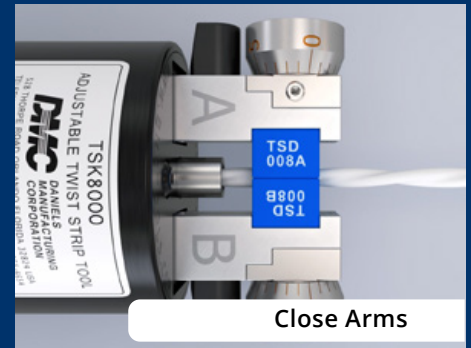

Close Arms

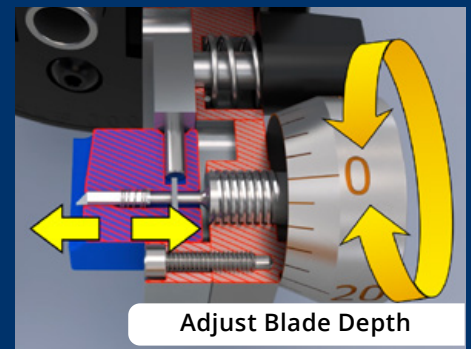

Adjust Blade Depth



Strip Cable Jacket



Completed Strip

Tool Kits

DMC works to provide the most comprehensive solutions for high speed data and shielded, twisted, multi-conductor cable preparation.

TSK8000: Twist Strip Kit* with TSK8000 M32610/01-01 Only

TSK8001: Twist Strip Kit* with TSK8000 w/All (12) 1 Conductor Die Sets (Cable DIA range 0.061" to 0.180")

TSK8002: Twist Strip Kit* with TSK8000 M32610/01-23 w/All (10) 2 Conductor Die Sets (Cable DIA range 0.081" to 0.180")
TSK8002 has an NSN# 5110-01-677-3943

TSK8003: Twist Strip Kit* with TSK8000 M32610/01-24 w/All (10) 3 Conductor Die Sets (Cable DIA range 0.081" to 0.180")

TSK8004: Twist Strip Kit* with TSK8000 w/All (9) 4 Conductor Die Sets (Cable DIA range 0.091" to 0.180")

TSK8023: Twist Strip Kit* with TSK8000 M32610/01-25 w/All (20) 2 & 3 Conductor Die Sets (Cable DIA range 0.081" to 0.180")

TSK8500: Twist Strip Kit* with TSK8500 Only

TSK8501: Twist Strip Kit* with TSK8500 w/All (13) 1 Conductor Die Sets (Cable DIA range 0.181" to 0.310")

TSK8502: Twist Strip Kit* with TSK8500 w/All (13) 2 Conductor Die Sets (Cable DIA range 0.181" to 0.310")

TSK8503: Twist Strip Kit* with TSK8500 w/All (13) 3 Conductor Die Sets (Cable DIA range 0.181" to 0.310")

TSK8504: Twist Strip Kit* with TSK8500 w/All (13) 4 Conductor Die Sets (Cable DIA range 0.181" to 0.310")

TSK8523: Twist Strip Kit* with TSK8500 w/All (26) 2 & 3 Conductor Die Sets (Cable DIA range 0.181" to 0.310")

**Includes case, TS8000 and TS8500 CIC Cable Diameter Gauge Card, and accessories; in an organized, foam-lined insert. Individual die set part numbers are listed on page 3.*



Die Set Container



TSK8000 (Kit)
Die Sets Sold Separately



TSK8500 (Kit)
Die Sets Sold Separately

Selecting the Correct Die Set

First the user must determine the "lay" of the sample cable. See illustration on right.

The Cable Diameter Gauge Card should be utilized to select a die set. The max OD and part number of the appropriate die set are shown next to each opening. Find the smallest opening in the gauge card that the cable freely passes through without getting snagged or stuck.



Cable Diameter Gauge Card

Left Hand Lay
"S" Direction



Right Hand Lay
"Z" Direction



Notes and Specifications

Important Notes

- The “starting depth” for blade adjustment produces a very light score on cable jacket. Operator should adjust cutting depth to preferred depth setting.
- 3 conductor die sets have a non-concentric shape. Therefore, 3 conductor die sets come with only 1 blade. The blade is in the “B” side die. This will produce a single cut longitudinally on the cable.
- Tool allows for .001” incremental adjustments to blade cutting depth.
- Cutting blade depth adjustments are critical for correct performance. Cutting too deep into the cable will damage it beyond repair. Small incremental adjustments reduce potential damage.
- Cable diameter and the # of inner conductors is critical to tool performance. Die sets should be matched to proper cable diameter and # of inner conductors using the chart above.
- In some circumstances a larger die cavity may be needed to accommodate wire that is at the maximum OD for the measured cable part number.
- Universal dies above are designed for cable with a left twist. Dies designed for cable with a right twist have an “R” in the part number: TSRXXXX and TSLRXXXX
- Soft insulation may cause the cable to jam or stick during the stripping operation. Certain applications may not be suited for this tool.
- Certain applications may need a custom die set. If die sets above are not suitable, call DMC at (407) 855-6161 for assistance.

Specifications

TS8000 Tool Specifications:

- The TS8000 accommodates a variety of multi-conductor cable having diameters from 0.061” to 0.180”
- Strips the outer jacket of shielded twisted multi-conductor, and round cable
- End stripping or window stripping of cable as needed
- Interchangeable stripping dies (with cable track and carbide blade set)
- Adjustable blade depth settings
- Tool Weight: .81 lbs
- Shipping Weight: 2lbs (includes entire tool and accessories in foam lined case)
- Die Arm Lever Force: 4.4 lbs
- Die Arm Lever Length: 1”
- Tool Dimensions: 1.75” wide, 9.75” tall
- Cable Max OD: < 0.180”
- Cable Min OD: > 0.081”

TS8500 Tool Specifications:

- TS8500 accommodates a variety of multi-conductor cable having diameters from 0.181” to 0.310”
- Strips the outer jacket of shielded twisted multi-conductor, and round cable
- End stripping or window stripping of cable as needed
- Interchangeable stripping dies (with cable track and carbide blade set)
- Adjustable blade depth settings
- Tool Weight: .81 lbs
- Shipping Weight: 2lbs (includes entire tool and accessories in foam lined case)
- Die Arm Lever Force: 4.4 lbs
- Die Arm Lever Length: 1”
- Tool Dimensions: 1.75” wide, 9.75” tall
- Cable Max OD: < 0.310”
- Cable Min OD: >.181”

NEMA WC 27500 Shielded & Unshielded Cable Part Numbering

(Example: M27500-20SB3T23)

M27500	-	20	SB	3	T	23
SPECIFICATION NUMBER	-	CONDUCTOR SIZE	Basic Wire Specification	NUMBER OF CONDUCTORS	Shield Description	Jacket Type

Jacket Material

Single Jacket	Double Jacket	Jacket Material	Temp. Rating
00	00	No Jacket	-
01	51	Extruded white PVC	90°C
02	52	Extruded clear nylon	105°C
03	53	White polyimide braid impregnated with clear polyimide finisher over a polyester tape	105°C
04	54	Polyester braid impregnated with high temperature finishers over polyester tape	105°C
05	55	Extruded clear FEP	200°C
06	56	Taped PTFE	260°C
07	57	White taped PTFE	260°C
08	58	Extruded white irradiated PVDF	150°C
09	59	Extruded white FEP	200°C
10	60	Extruded clear PVDF	125°C
11	61	Wrapped FEP	200°C
12	62	Tape of natural polyimide combined with FEP wrapped and heat sealed	150°C
14	64	Extruded white ETFE	150°C
15	65	Extruded clear ETFE	150°C
16	66	Taped PTFE	200°C
17	67	Extruded ECTFE	150°C
18	68	Clear Extruded ECTFE	150°C
20	70	Extruded white PFA	260°C
21	71	Extruded clear PFA	260°C
22	72	Tape of polyimide combined with clear FEP wrapped and heat sealed	200°C
23	73	Extruded white irradiated ETFE	200°C
24	74	PTFE wrapped over a tape layer of natural polyimide combined with FEP and heat sealed	200°C

NEMA WC 27500 Shielded & Unshielded Cable Part Numbering

(Example: M27500-20SB3T23)

M27500	-	20	SB	3	T	23
SPECIFICATION NUMBER	-	CONDUCTOR SIZE	Basic Wire Specification	NUMBER OF CONDUCTORS	Shield Description	Jacket Type

Jacket Material

Single Jacket	Double Jacket	Jacket Material	Temp. Rating
00	00	No Jacket	-
01	51	Extruded white PVC	90°C
02	52	Extruded clear nylon	105°C
03	53	White polyimide braid impregnated with clear polyimide finisher over a polyester tape	105°C
04	54	Polyester braid impregnated with high temperature finishers over polyester tape	105°C
05	55	Extruded clear FEP	200°C
06	56	Taped PTFE	260°C
07	57	White taped PTFE	260°C
08	58	Extruded white irradiated PVDF	150°C
09	59	Extruded white FEP	200°C
10	60	Extruded clear PVDF	125°C
11	61	Wrapped FEP	200°C
12	62	Tape of natural polyimide combined with FEP wrapped and heat sealed	150°C
14	64	Extruded white ETFE	150°C
15	65	Extruded clear ETFE	150°C
16	66	Taped PTFE	200°C
17	67	Extruded ECTFE	150°C
18	68	Clear Extruded ECTFE	150°C
20	70	Extruded white PFA	260°C
21	71	Extruded clear PFA	260°C
22	72	Tape of polyimide combined with clear FEP wrapped and heat sealed	200°C
23	73	Extruded white irradiated ETFE	200°C
24	74	PTFE wrapped over a tape layer of natural polyimide combined with FEP and heat sealed	200°C