

# DANIELS STANDARD HD51 HYDRAULIC CRIMP TOOL

**DMC** DANIELS  
MANUFACTURING  
CORPORATION  
DATASHEET

SEE PAGE 3 FOR IMPORTANT INFORMATION CONCERNING  
LIMITED WARRANTY, AND LIMITATION OF LIABILITY

## Introduction:

This datasheet covers the proper use of the HD51 hydraulic crimp tool. Read the information contained herein carefully before using the tool.

## Description:

The hydraulic tool is operated by pumping both handles. It can be operated with one hand by laying the stationary handle on a flat surface. It has a force of 5.5 tons and weighs 4.6 lbs. It also has a 180° rotating head for easy accessibility in confined working areas.

## Selection of Crimping Die:

Determine proper crimping die set to be used for the crimp. Consult the factory for standard die sets. Custom die sets can be designed by DMC for almost any application.

## Operating Procedures:

1. Open the head and insert the crimping dies. The head assembly has two slots to slide the dies in and out safely.
2. Lock the head over the connector and pump the handle until the pressure relief valve is actuated and a sound is heard.

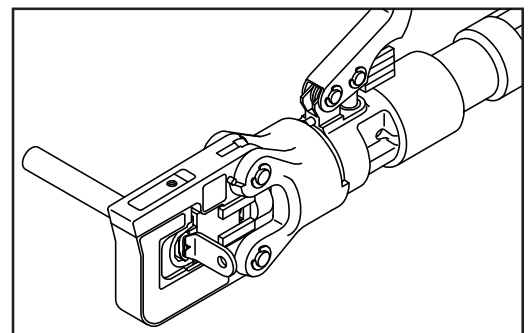
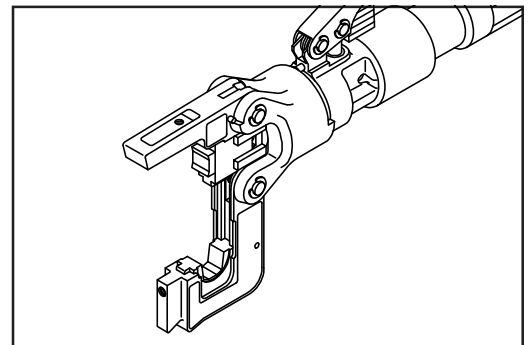
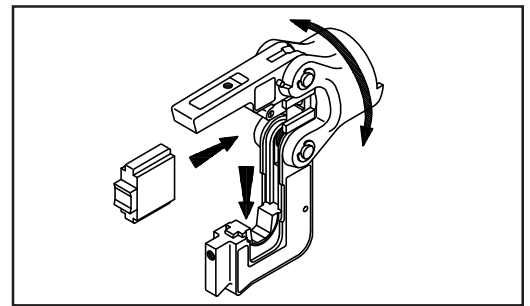
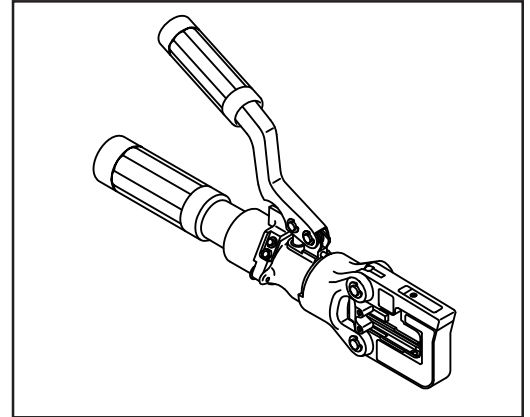

3. Activate the pressure release trigger to retract the hydraulic ram.

**Warning:** *Do not press the pressure release trigger until a sound is heard and the crimp is complete. Damage to tool will occur if mechanism is released before crimp is completed. Do not work the tool without dies.*

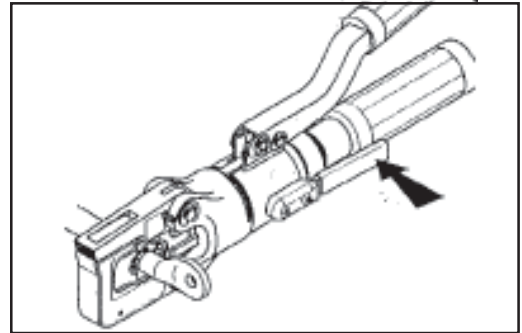

4. To remove the dies, open the head and remove dies by sliding along the slot.

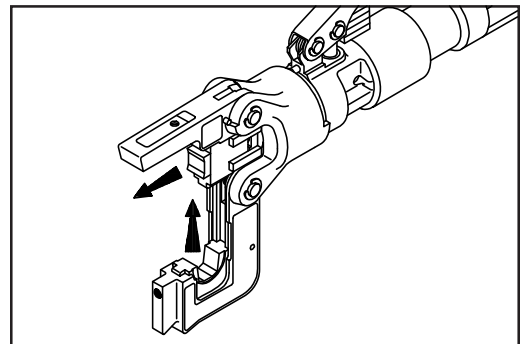

#### Refilling the Reservoir and Bleeding the Tool:

1. Fit a set of dies into the tool, depress the handle until dies are closed, or as far as dies will close.
2. Invert the tool and allow air to rise to the top of the reservoir.
3. Back out set screw holding reservoir cover in place.
4. Unscrew the reservoir cover and remove filler plug. Fill with oil.
5. Depress the release trigger. Excess oil will be ejected from the reservoir as the ram retracts.
6. Replace the filler plug and reservoir cover.
7. Tighten set screw holding reservoir cover in place.
8. Perform two (2) full closures with the tool inverted.

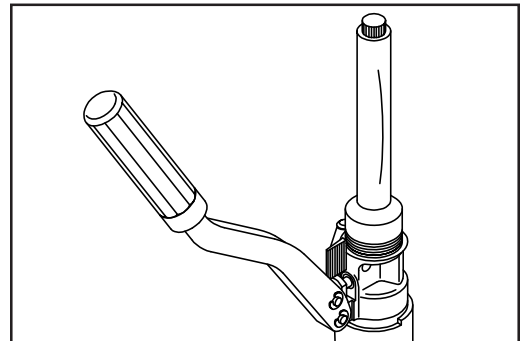

**Daniels offers complete refurbishing and recalibration services. DMC also specially engineers and manufactures complete tool kits to satisfy individual customer requirements, such as total aircraft support, general shop maintenance or production, on board ship and vehicle service, etc.**

### **LIMITATION OF LIABILITY**

Daniels Manufacturing Corporation (DMC) is not liable for consequential or special damages of any nature or kind resulting from the use, or misuse, of any of its products. Owners and users of (DMC) products assume full responsibility for instructing their employees in the proper and safe use of such products.

### **LIMITED WARRANTY**

Daniels Manufacturing Corporation (DMC) warrants each new product sold by it to be free from defects in material and workmanship under normal use and service. DMC's obligation under this warranty is limited to the free correction or, at DMC's option, the refund of the purchase price of any such product which proves defective in normal service within ninety (90) days after delivery to the first user, provided that the product is returned to DMC with all transportation charges prepaid in which shall appear to DMC's satisfaction, after DMC's inspection, to have being defective in material or workmanship, it being understood that DMC products are not consumer products. This warranty shall not cover any damage to any product which, in the opinion of DMC, was caused by normal wear, misuse, improper operation, tampering, neglect or accident. This warranty is in lieu of all other warranties express or implied. No warranty, express or implied, is made or authorized to be made or assumed with respect to products of Daniels Manufacturing Corporation other than those herein set forth.