

USERS MUST ASSURE THEY ARE USING THE CORRECT REVISION.

REVISIONS

REV	ECO NO.	DESCRIPTION	BY	DATE	APP'D BY	DATE
1		ORIGINAL RELEASE	K. KOONS	4/10/2015		
2		ADDED SAFETY WIRE ROPE ASSEMBLY	K. KOONS	5/9/2017		

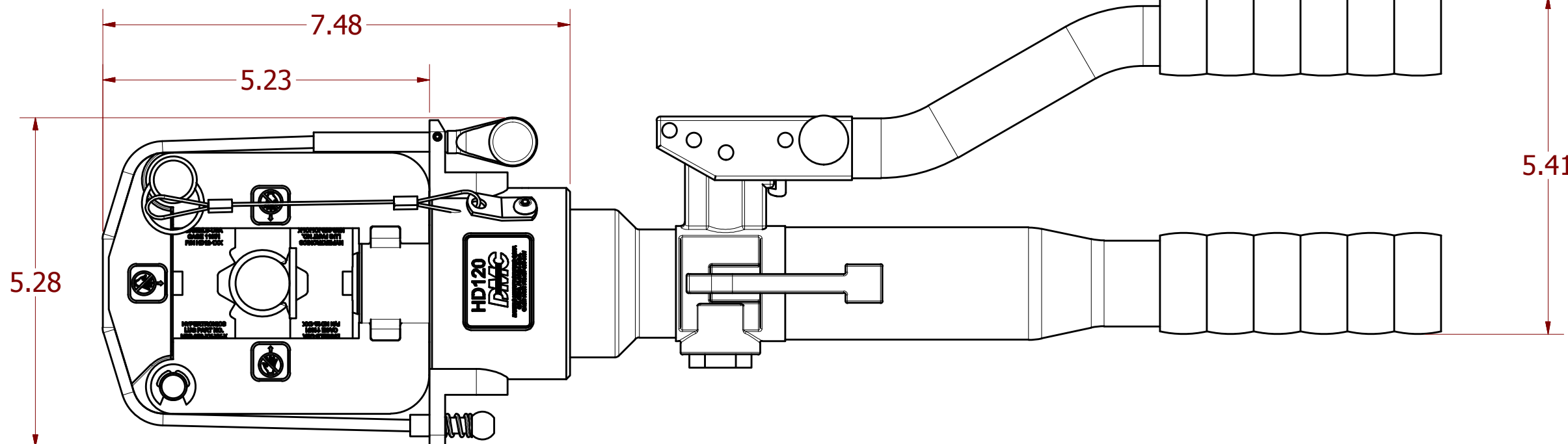
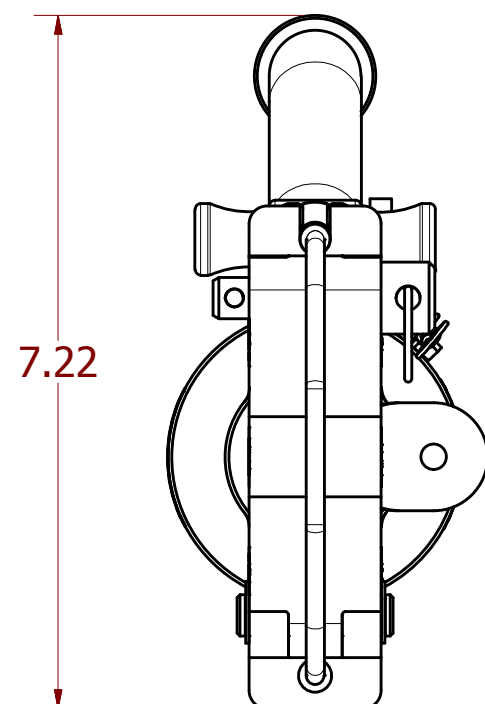
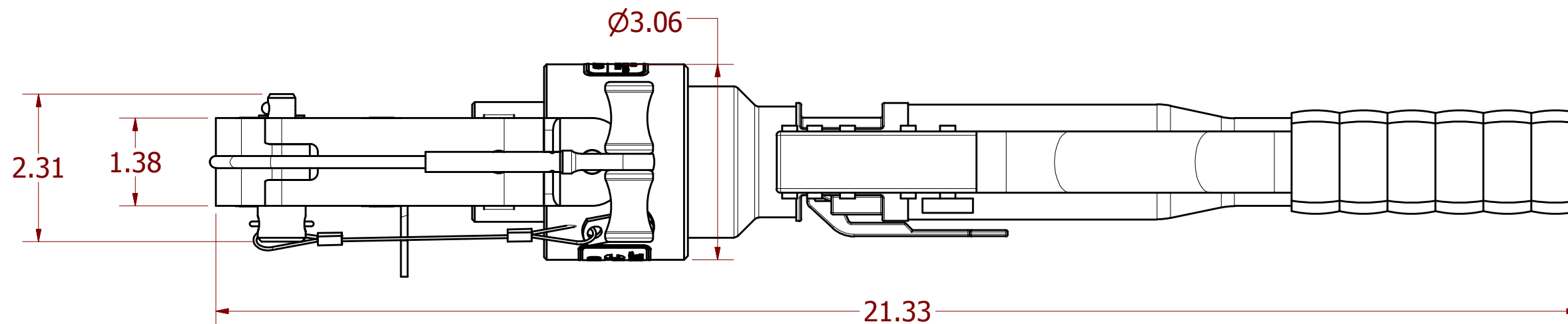

1. APPROXIMATE WEIGHT 14.5lb.
NOTES:

MATERIAL	ITEM	PART NO.	QTY.	DESCRIPTION / REMARKS
NA	DRN. KIRK C KOONS CHK'D. TLM	DATE 1/29/2015 DATE 2/1/2016		DMC DANIELS MANUFACTURING CORP. ORLANDO, FLORIDA CAGE 11851
RESTRICTED & CONFIDENTIAL CONFIDENTIAL PROPERTY OF DANIELS MANUFACTURING CORP. NOT TO BE DISCLOSED TO OTHERS. REPRODUCTION OR USED FOR ANY OTHER PURPOSE EXCEPT AS AUTHORIZED IN WRITING BY DANIELS MANUFACTURING. MUST BE RETURNED TO DANIELS MANUFACTURING CORP. ON COMPLETION OF ORDER OR PURPOSES FOR WHICH LENT.	HEAT TREAT	NOTE: THIS DRAWING IS AN OUTLINE DRAWING OF THE RESPECTIVE DMC PART NUMBER INDICATED. ACTUAL DMC PART NUMBER IS CAD PART NUMBER WITHOUT THE "-ENV" SUFFIX	TITLE HYDRAULIC CRIMP TOOL, 12 TON ENVELOPE DRAWING	
CREATED FROM AN INVENTOR MODEL. CHANGES MUST BE REFLECTED IN THE 3D PART	FINISH	NA	WHERE USED: SIZE B SCALE 1 / 2 CAD P/N HD120-ENV SHEET 1 OF 1	REV. 2
DO NOT SCALE DRAWING			DWG. NO. HD120	